

Owner's Manual

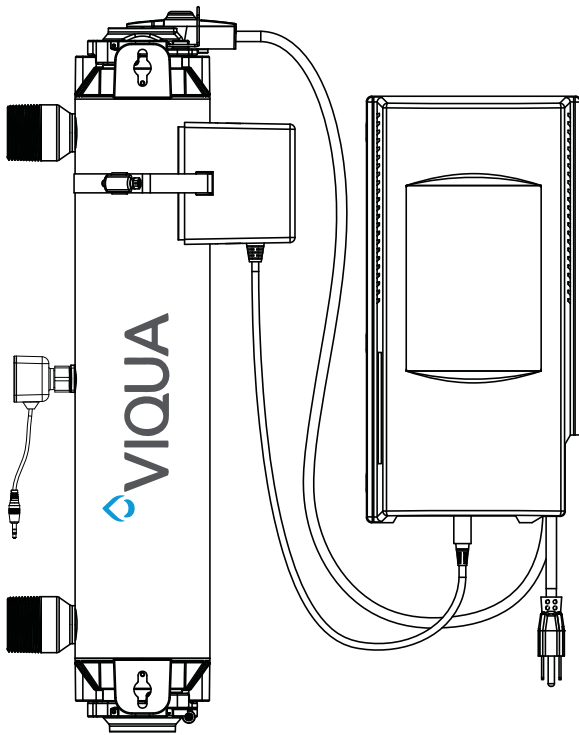

Models:

H, K

Plus Models:

H+, K+

PRO Models:

PRO10, PRO20, PRO30, PRO50

Powered by



425 Clair Rd. W, Guelph, Ontario, Canada N1L 1R1
t. (+1) 519.763.1032 • tf. (+1) 800.265.7246 (US and Canada only)
t. (+31) 73 747 0144 (Europe only) • f. (+1) 519.763.5069
e-mail: info@viqua.com
www.viqua.com



System Tested and Certified by
NSF International against CSA
B483.1 and NSF/ANSI 55 for
Disinfection Performance, Class A



MEMBER



Congratulations

on the purchase of your ultraviolet (UV) water disinfection system! This system uses the most advanced UV technology on the market and is designed to provide you with years of trouble free operation with minimal maintenance required to protect your drinking water from microbiological contaminants.

To ensure ongoing disinfection of your water, UV lamps need to be replaced annually with VIQUA factory-supplied replacements. VIQUA lamps are the result of extensive development resulting in a highly efficient disinfection platform with extremely stable UV output over the entire 18000 hour lifetime. Its success has led to a proliferation of non-genuine copies in the market.

The UV lamp is the heart of the disinfection system, and there should be no compromise when it's time for a replacement.

Why should you insist on genuine factory supplied VIQUA replacement lamps?

- Use of widely available, non-genuine, replacement lamps has been shown to damage the control module of VIQUA UV disinfection equipment.
- An increasing number of calls to VIQUA Technical Support are connected with non-genuine lamps being used (unknowingly) as replacements.
- Damage arising from the use of non-genuine lamps poses a safety risk and is not covered by equipment warranty.
- Unless the UV equipment is equipped with a UV sensor (monitor), it is not possible to verify the UV (invisible) output of replacement lamps.
- Similar appearance to the original lamp and the presence of (visible) blue light does not mean equivalent disinfection performance.
- VIQUA replacement lamps undergo rigorous performance testing and strict quality control processes to ensure that the safety and performance certifications of the original equipment are not compromised.

So, you can see that it's simply not worth the risk! Insist on genuine VIQUA replacement lamps.

















Section 1 Safety Information

These are the original instructions. Please read this entire manual before operating this equipment. Pay attention to all danger, warning, and caution statements in this manual. Failure to do so could result in serious personal injury or damage to the equipment.

Make sure that the protection provided by this equipment is not impaired. DO NOT use or install this equipment in any manner other than that specified in the installation manual.



1.1 Potential Hazards:

Read all labels and tags attached to the system. Personal injury or damage to the system could occur if not observed.

	Waste electrical and electronic equipment (WEEE). This symbol indicates that you should not discard wasted electrical or electronic equipment (WEEE) in the trash. For proper disposal, contact your local recycling/reuse or hazardous waste center.		This symbol indicates not to store any combustible or flammable material close to the system.
	This symbol indicates there is Mercury present.		This symbol indicates that the contents of the transport package are fragile and the package should be handled with care.
	This is the safety alert symbol. Obey all safety messages that follow this symbol to avoid potential injury. When on the equipment, refer to the Operational and Maintenance manual for additional safety		This symbol indicates safety glasses with side protection is required for protection against UV exposure.
	This symbol indicates a risk of electrical shock and/or electrocution exists.		This symbol indicates gloves must be worn.
	This symbol indicates the marked equipment may contain a component that can eject forcibly. Obey all procedures to safely depressurize.		This symbol indicates safety boots must be worn.
	This symbol indicates the system is under pressure.		This symbol indicates the operator must read all available documentation to perform required procedures.
	This symbol indicates there is a potential UV hazard. Proper protection must be worn.		This symbol indicates the plumber must use copper piping.
	This symbol indicates the marked item could be hot and should not be touched without care.		This symbol indicates that the system should only be connected to a properly grounded, grounding-type controller receptacle that is protected by a Ground Fault Circuit Interrupter (GFCI).
	This symbol indicates there is a potential for VERY hot water when flow is started.		

Warning: This product may contain chemicals known to the State of California to cause cancer and birth defects or other reproductive harm.

1.2 Safety Precautions:

⚠ DANGER	
 	<p>Failure to follow these instructions will result in serious injury or death.</p> <ul style="list-style-type: none"> • Electric Shock: To avoid possible electric shock, special care should be taken since water is present near the electrical equipment. Unless a situation is encountered that is explicitly addressed by the provided maintenance and troubleshooting sections, DO NOT attempt repairs yourself, refer to an authorized service facility. • GROUNDING: This product must be grounded. If it should malfunction or breakdown, grounding provides a path of least resistance for electric current to reduce the risk of electrical shock. This system is equipped with a cord having an equipment-grounding conductor and a grounding plug. The plug must be plugged into an appropriate outlet that is properly installed and grounded in accordance with all local codes and ordinances. Improper connection of the equipment-grounding conductor can result in a risk of electrocution. Check with a qualified electrician or service personnel if you are in doubt as to whether the outlet is properly grounded. DO NOT modify the plug provided with this system – if it does not fit in the outlet, have a proper outlet installed by a qualified electrician. DO NOT use any type of adapter with this system. • GROUND FAULT CIRCUIT INTERRUPTER PROTECTION: To comply with the National Electrical Code (NFPA 70) and to provide additional protection from the risk of electric shock, this system should only be connected to a properly grounded, grounding-type controller receptacle that is protected by a Ground Fault Circuit Interrupter (GFCI) or to a residual current device (RCD) having a rated residual operating current not exceeding 30 mA. Inspect operation of GFCI as per manufacturer’s suggested maintenance schedule. • DO NOT operate the disinfection system if it has a damaged cord or plug, if it is malfunctioning or if it has been dropped or damaged in any manner. • DO NOT use this disinfection system for other than intended use (potable water applications). The use of attachments not recommended or sold by the manufacturer / distributor may cause an unsafe condition. • DO NOT install this disinfection system where it will be exposed to the weather or to temperatures below freezing. • DO NOT store this disinfection system where it will be exposed to the weather. • DO NOT store this disinfection system where it will be exposed to temperatures below freezing unless all water has been drained from it and the water supply has been disconnected.

Safety Information

⚠ WARNING



- During extended periods of no water flow, the water in your chamber can become very hot (Approx. 60 °C) and potentially lead to scalding. It is recommended to run your water until this hot water has been purged from your chamber. Do not allow water to contact your skin during this time. To eliminate this condition, a temperature management valve can be installed at the outlet of your UV system.
- Do not pass water through the UV system for a minimum of 5 minutes after applying power (including after power interruptions) to avoid passing under-treated water that may, in rare instances, pose health hazards.
- This system contains a UV Lamp. Do not operate the UV Lamp when it is removed from the chamber. Unintended use or damage of the system may result in the exposure of dangerous UV radiation. UV radiation may, even in little doses, cause harm to the eyes and skin.
- Changes or modifications made to this system without the consent of the manufacturer could render the system unsafe for operation and may void the manufacturer's warranty.

⚠ CAUTION



Failure to follow these instructions could result in minor or moderate injury.

- Double pole/Neutral fusing.
- Carefully examine the disinfection system after installation. It should not be plugged in if there is water on parts not intended to be wet such as, the controller or lamp connector.
- Due to thermal expansion concerns and potential material degradation due to UV exposure, it is recommended to use metal fittings and at least 10" of copper pipe on the outlet of your UV chamber.
- **Hg EXPOSURE:** The UV lamp contains mercury. If the lamp breaks, then avoid inhalation or ingestion of the debris and avoid exposure to eyes and skin. Never use a vacuum cleaner to clean up a broken lamp as this may scatter the spilled mercury. Obey local regulations and guidelines for the removal and disposal of mercury waste.

NOTICE



- The UV lamp inside the disinfection system is rated at an effective life of approximately 18000 hours. To ensure continuous protection, replace the UV lamp once in two years.
- The UV system is not to be used or played with by children. Persons with reduced physical, sensory or mental capabilities, or lack of experience and knowledge, are also not to handle the UV system unless they have been given supervision or instruction.
- This system is intended to be permanently connected to the water lines.
- This system is not intended to be used in or above water or outdoors or used in swimming pools when persons are in the pool.
- **EXTENSION CORDS:** If an extension cord is necessary, use only 3-wire extension cords that have 3-prong grounding-type plugs and 3-pole cord connectors that accept the plug from this system. Use only extension cords that are intended for outdoor use. Use only extension cords having an electrical rating not less than the rating of the system. A cord rated for less amperes or watts than this system rating may overheat. Exercise caution when arranging the cord so that it will not be tripped over or pulled. DO NOT use damaged extension cords. Examine extension cord before using and replace if damaged. DO NOT abuse extension cord. Keep extension cord away from heat and sharp edges. Always disconnect the extension cord from the receptacle before disconnecting this system from the extension cord. Never yank cord to pull plug from outlet. Always grasp the plug and pull to disconnect.
- If the supply cord is damaged, it must be replaced by a special cord or assembly available from the manufacturer or its service agent.
- **SYSTEM PROTECTION:** To protect your Controller, a UL1449 certified (or equivalent) transient voltage surge suppressor is strongly recommended.
- The UV lamp in this system conforms to the applicable provisions of the Code of Federal Regulations (CFR) requirements including, Title 21, Chapter 1, Subchapter J, Radiological Health.
- Read and understand the Owner's Manual before operating and performing any maintenance on this equipment.

1.3 Water Chemistry

Water quality is extremely important for the optimum performance of your UV system. The following levels are recommended for installation:

Water Quality and Minerals	Level
Iron	< 0.3 ppm (0.3 mg/L)
Hardness*	< 7 gpg (120 mg/L)
Turbidity	< 1 NTU
Manganese	< 0.05 ppm (0.05 mg/L)
Tannins	< 0.1 ppm (0.1 mg/L)
UV Transmittance	> 75% (call factory for recommendations on applications where UVT < 75%)

* Where total hardness is less than 7 gpg, the UV unit should operate efficiently provided the quartz sleeve is cleaned periodically. If total hardness exceeds 7 gpg, the water should be softened. If your water chemistry contains levels in excess of those mentioned above, proper pre-treatment is recommended to correct these water problems prior to the installation of your UV disinfection system. These water quality parameters can be tested by your local dealer, or by most private analytical laboratories. *Proper pre-treatment is essential for the UV disinfection system to operate as intended.*

Section 2 General Information

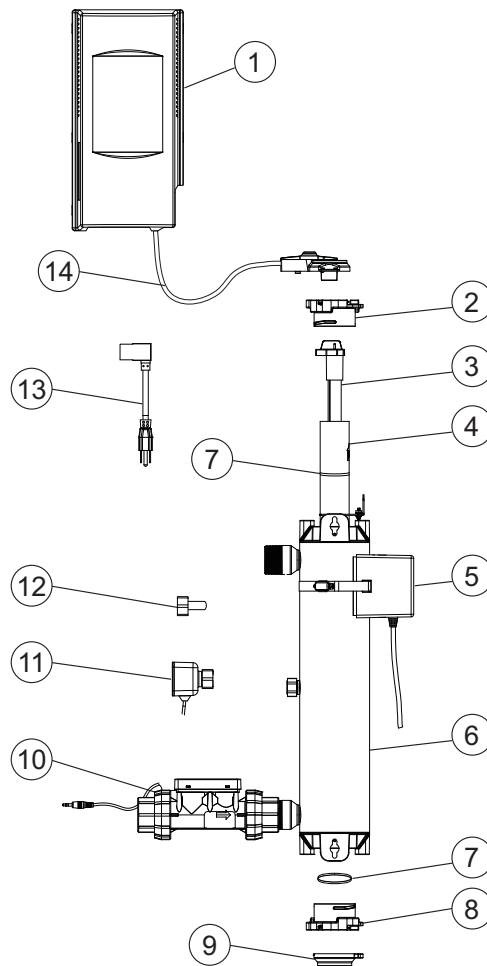

Figure 1 System Components

Item	Description	Part Number	UV Systems
1	Controller	650709-003	PRO10
		650709-006	PRO20
		650709-009	PRO30
		660020-R	PRO50
		650709-005	H+
		660019-R	K+
		650709-004	H
		660018-R	K
2	Top Bolt and Wireform	602916 & 602896	Used for all systems
3	Lamp	602854	PRO10
		602855	PRO20, H+, H
		602856	PRO30/50, K+, K
4	Sleeve	602974	PRO10
		602975	PRO20, H+, H
		602976	PRO30/50, K+, K
5	CoolTouch Fan	650630	Used for all systems
6	Chamber	-	Used for all systems
7	O-ring	002233	Used for all systems

General Information

8	Bottom bolt (includes screw)	603053	Used for all systems
9	Sleeve Removal Tool	602988	Used for all systems
10	Flow Meter Sensor (PRO models only)	410982R-10	PRO10
		410982R-20	PRO20
		410982R-30	PRO30
11	Sensor	650580	PRO and Plus models
12	Plug	-	Basic models
13	Power cord	602636	110V - Used for all systems
		602637	220V - Used for all systems
14	Lamp cord	-	Used for all systems

2.1 Dimensions and Layout

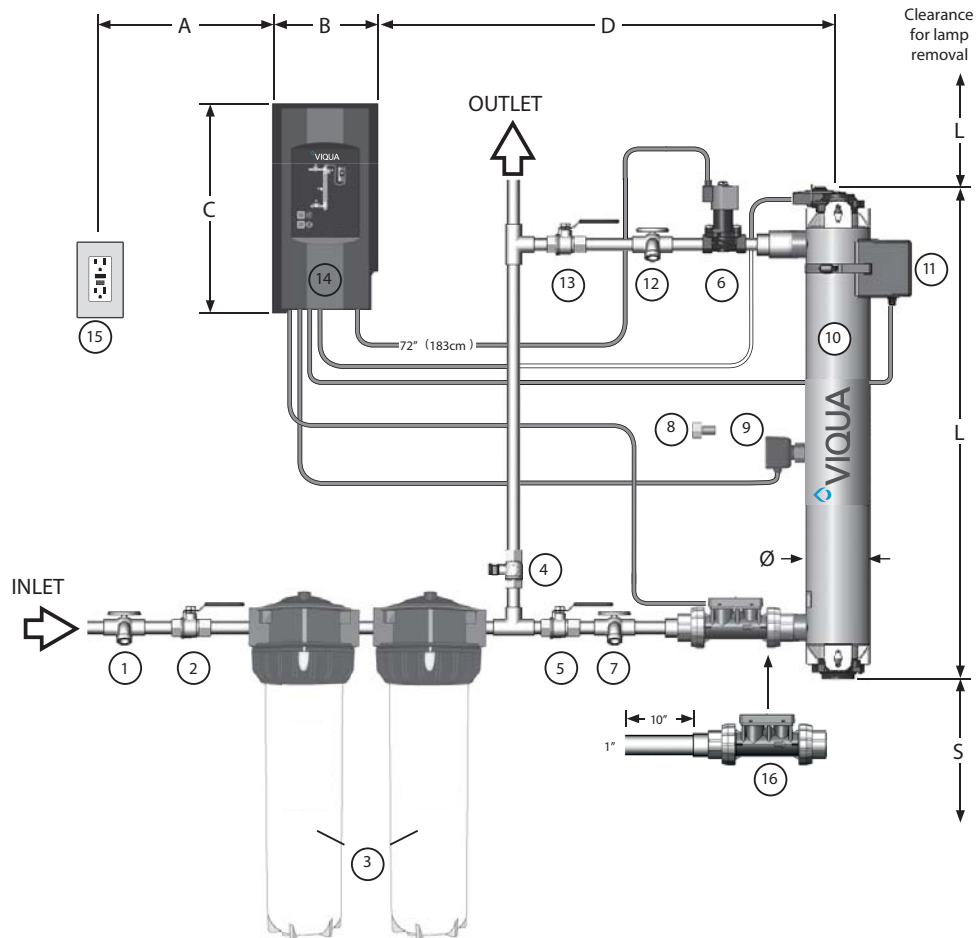

Figure 2 System - Dimension and Layout

Item	Description	Function
1	Sample Valve	Allows for sampling of raw water.
2	Shut-off Valve	Allows for ease of maintenance of pre-treatment equipment.
3	Pre-Treatment	Pre-treatment allows the UV system to operate effectively. The water should meet certain water quality parameters before entering UV System.
4	Bypass shut-off valve:	Bypass line and valve are optional. Intended to provide emergency water supply in the event that the UV system is unavailable.
5	Shut-off valve	Required to allow maintenance of UV system.

6	Solenoid valve	Allows water supply to be shut-off when proper disinfection cannot be assured. Note: If the ground from your electrical panel is tied to your copper water lines, and you are using a Plastic Body solenoid valve, installation of an approved ground strap is required. This ground strap will maintain continuity between the lines that have been cut to install the solenoid. Check your local electrical code for the correct clamp and cable size.
7	Sample valve	Allows for sampling of water entering UV chamber; necessary in order to confirm water being treated is of adequate quality.
8	Plug	A stopper provided and installed on Basic models.
9	Sensor	Monitors UV output to ensure proper dose (UV exposure) is being provided.
10	UV chamber	Provides disinfection of the water. MUST BE INSTALLED VERTICALLY.
11	CoolTouch™ fan	Removes excess heat from water in chamber during periods without water flow.
12	Sample valve	Allows for sampling of water immediately following UV treatment; necessary in order to confirm proper operation of UV system.
13	Shut-off valve	Allows maintenance of UV system.
14	Controller	Powers and controls the UV lamp and other devices. Provides human interface, displaying information and allowing control inputs (such as muting the audible alarm).
15	Power source	Provides power to the controller. For safety reasons the outlet must be protected by a Ground Fault Circuit Interrupter (GFCI). Note: To protect the controller, a UL1449 certified (or equivalent) transient voltage surge suppressor is required.
16	Flow Sensor	Monitors flow to provide real time dose (UV exposure) Flow Meter Sensor must be installed in this orientation with the LED facing up. (PRO10, PRO20, PRO30 only)

Item	L	S (minimum)	O	A (maximum)	B	C	D
PRO10	21.4" (55 cm)	12" (30 cm)	4" (10 cm)	72" (182 cm)	6.5" (16.5 cm)	13" (33 cm)	48" (122 cm)
PRO20, H+, H	31" (78 cm)	12" (30 cm)	4" (10 cm)	72" (182 cm)	6.5" (16.5 cm)	13" (33 cm)	48" (122 cm)
PRO30	41" (103 cm)	12" (30 cm)	4" (10 cm)	72" (182 cm)	6.5" (16.5 cm)	13" (33 cm)	48" (122 cm)
PRO50, K+, K	41" (103 cm)	12" (30 cm)	4" (10 cm)	72" (182 cm)	6.5" (16.5 cm)	13" (33 cm)	48" (122 cm)

2.2 Pipe Lengths

The recommended minimum straight pipe lengths for the various piping configurations are:



Straight Flange 10" straight pipe



Reducing Flange 15" straight pipe



2 x 90 degree Elbows 25" straight pipe



2 x 90 degree Elbows 3 dimensions 40" straight pipe

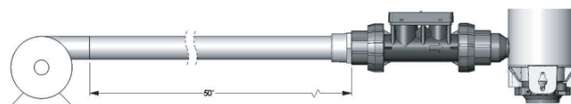

Pump 50" straight pipe

Note: Flow Meter Sensor must be mounted in the following orientation with the LED facing up. Ensure all air is purged from the piping and Flow Meter Sensor. All straight length to the Flow Meter Sensor must be 1.00" in diameter.

Section 3 Installation

3.1 Installing UV System

⚠ CAUTION



Electronic controller must be connected to a Ground Fault Protected Circuit (GFCI) receptacle.

Prerequisites:

- Determine appropriate indoor location of the controller and chamber, refer to [Section 2.1](#).
- Make sure that the controller is installed higher than the chamber and away from all water sources.
- Ensure adequate clearance above chamber to allow for removal of the lamp and sleeve.
- Make sure to turn off the main water supply.
- Make all necessary plumbing connections refer to [Section 2.1](#).

Procedure:

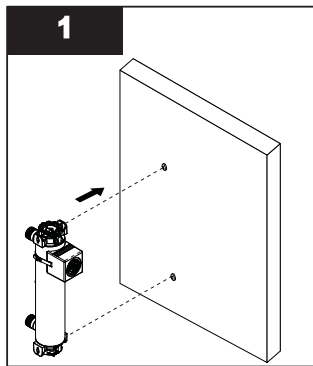

- Install the UV Chamber vertically with the following spacing on the wall using screws.
 - PRO10: 18.5"
 - H, PRO20: 27.5"
 - K, PRO30/50: 37.5"
- Note:** Ensure chamber is installed with green arrows pointing upwards.

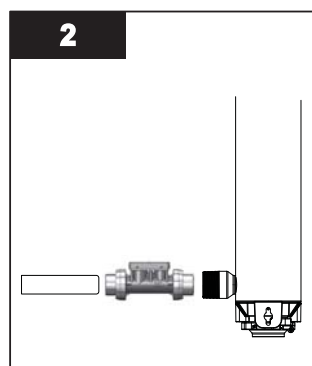

- Connect Flow Meter Sensor (PRO10,20,30 models only) to chamber using 1¼" unions supplied.
- Note:** LED must face up. Ensure proper length of straight pipe 1.0" Diameter at inlet side of Flow Meter Sensor and use a 1¼" to 1" Reducing Coupler (not supplied).

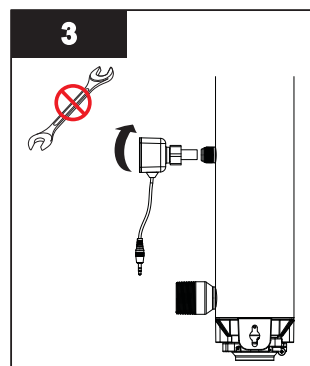

- Install the sensor to the UV system (for PRO models only).
- Note:** DO NOT use wrench to tighten the sensor.

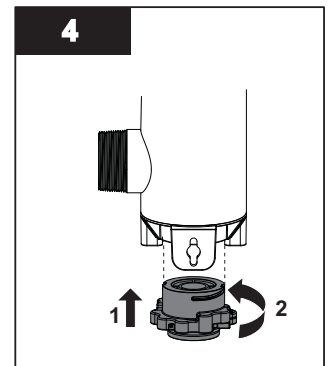

- Connect the sleeve bolt at the bottom of the sleeve assembly. Ensure sleeve bolt is rotated full 1/4 turn until positive stop.

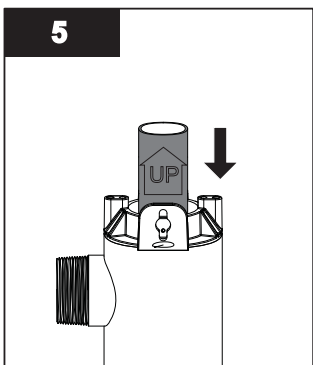

- Insert sleeve with arrow pointing up.
- Note:** DO NOT rotate sleeve and touch glass with bare hands.

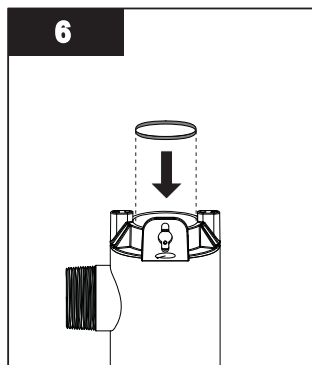

- Wet O-ring with water then place over top end of sleeve.

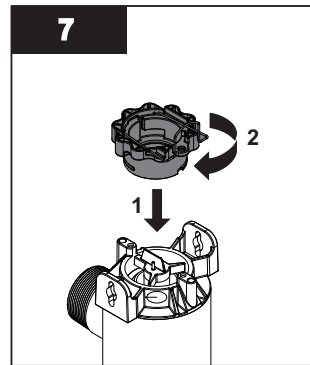

- Connect the sleeve bolt to the top of the sleeve assembly. Ensure sleeve bolt is rotated full 1/4 turn until positive stop.

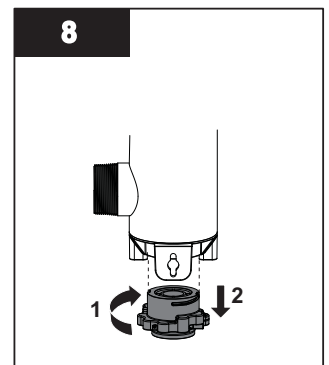

- Remove the sleeve bolt at the bottom of the sleeve assembly.

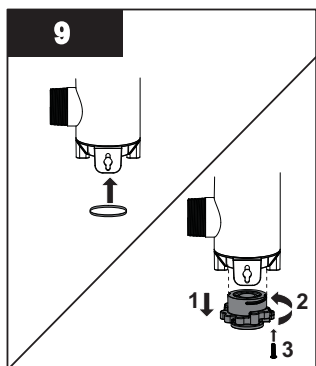

- Wet O-ring with water then place over bottom end of sleeve.
- Reconnect the sleeve bolt and install screw.

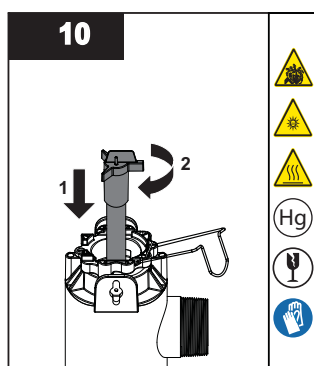

- Install and rotate the lamp into the sleeve assembly. Ensure to rotate the lamp completely.
- Note:** Do not touch glass with bare hands.

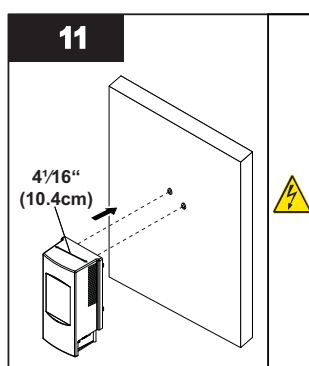

- Install the controller unit to the wall. Ensure that the controller is installed higher than the chamber and away from all water sources.

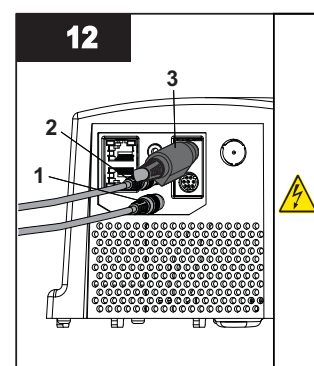

- Connect UV sensor into blue jack (For PRO and Plus models only).
- Connect Flow meter sensor into green jack (For PRO10, 20, 30 only).
- Connect CoolTouch™ fan into either receptacle.

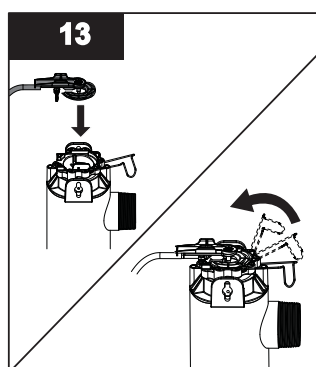

- Install lamp harness onto chamber.
- Notes:** 1) Ensure lamp harness ground is inserted into chamber ground terminal.
- 2) Ensure magnet on top of chamber aligns with proximity sensor on lamp harness.
- Lock wire form into position.

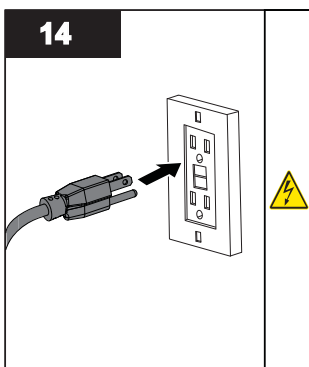

- Connect controller to power outlet.
- Note:** Lamp ignition may take up to 25 seconds.
 - Allow water flow to one faucet or other water outlet, then close the outlet and inspect for leaks.

Note: Outlet must be protected by a Ground Fault Circuit Interrupter (GFCI).

Note: After installing the UV lamp or sleeve perform the disinfection procedure, refer to [Section 3.2](#).

3.2 Disinfection Procedure

UV disinfection is a physical disinfection process and does not add any potentially harmful chemicals to the water. As UV does not provide a disinfection residual, it is imperative that the entire distribution system located after the UV be chemically disinfected to ensure that the plumbing system is free from any bacteriological contaminants. The disinfection process must be performed immediately after the UV unit is installed and repeated thereafter whenever the UV is shut down for service, without power, or inoperative for any reason. The procedure for sanitizing the plumbing system is readily accomplished as follows:

Procedure:

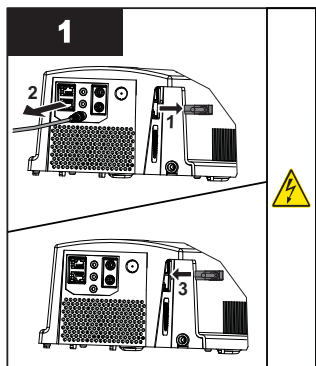

- Disconnect the controller then disconnect the UV sensor from blue jack.
- Reconnect the controller with out UV sensor.

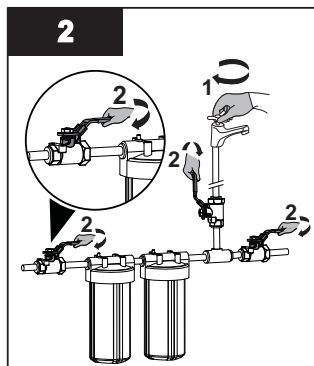

- Shut off the water supply.
- Open an upstream faucet to release line pressure

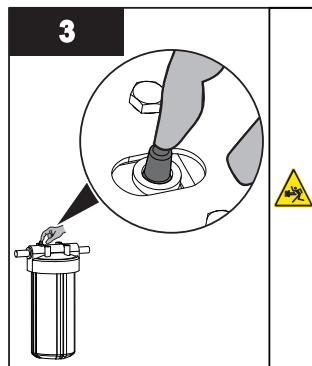

- Press the pressure button to release the pressure from the cartridges.

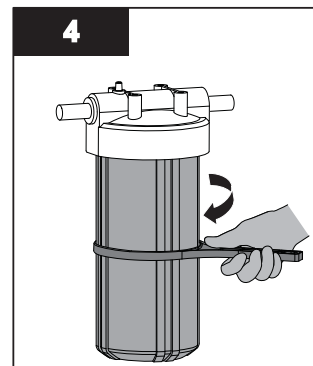

- Remove filter housing(s) using sump wrench.

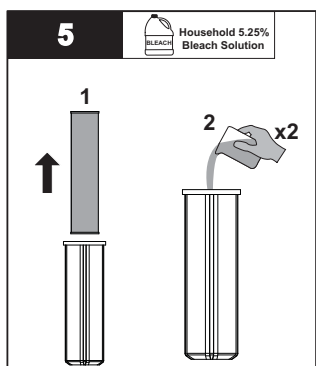

- Remove cartridge(s) and pour 2 cups of household bleach solution into the filter housing(s).

Note: DO NOT use Hydrogen Peroxide.

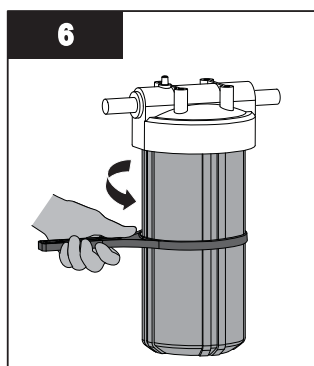

- Connect only the filter housing(s) to the unit.

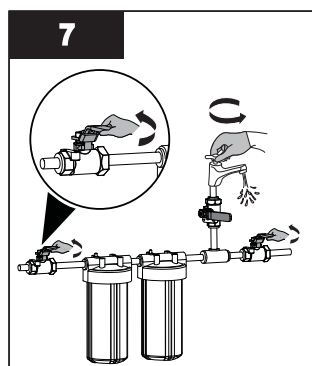

- Open each faucets and turn on water supply.
- Allow water to fill the chamber.

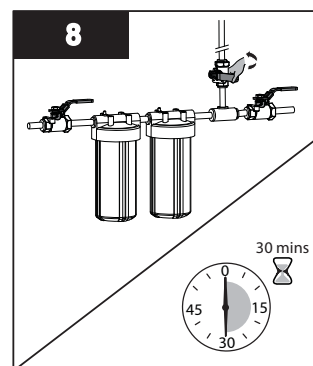

- Turn on the cold water supply followed by hot water (if available) until you smell the bleach.
- Close all faucets and allow bleach to settle in the water lines for 30 minutes.

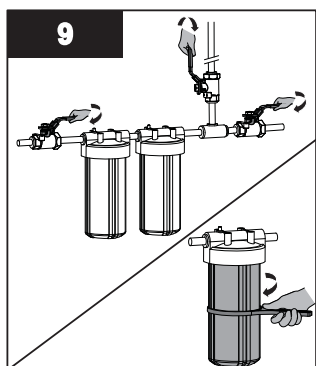

- With all faucets closed, remove filter housing(s) using sump wrench.

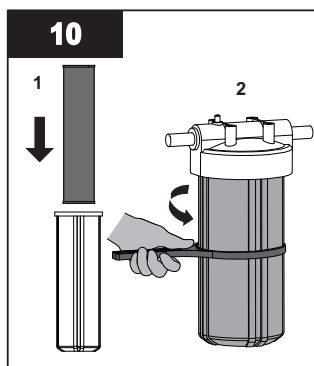

- Reinstall the cartridge(s) into filter housing(s) and connect to the unit.
- Flush all water outlets until bleach can no longer be smelled (at least 5 minutes).

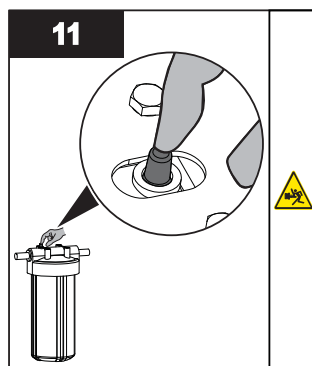

- Press the pressure button to purge air and to complete the disinfection procedure.

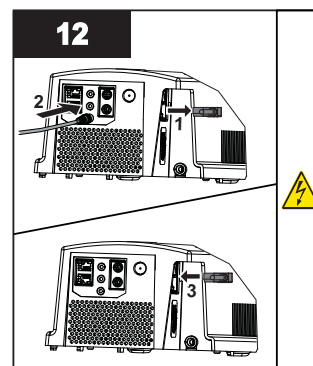

- Disconnect the controller then connect the UV sensor from blue jack.
- Reconnect the controller.

Section 4 Maintenance

⚠ WARNING



- Always disconnect power before performing any work on the disinfection system.
- Always shut-off water flow and release water pressure before servicing.
- Regularly inspect your disinfection system to ensure that the power indicators are on and no alarms are present.
- Replace the UV lamp biennially to ensure maximum disinfection.
- Always drain the chamber when closing a seasonal home or leaving the unit in an area subject to freezing temperatures.

4.1 Replacing UV Lamp

NOTICE

Do not use water during replacement of UV lamp.

UV lamp replacement is a quick and simple procedure requiring no special tools. The UV lamp must be replaced after 18000 hours of continuous operation (approximately two years) in order to ensure adequate disinfection.

Procedure:

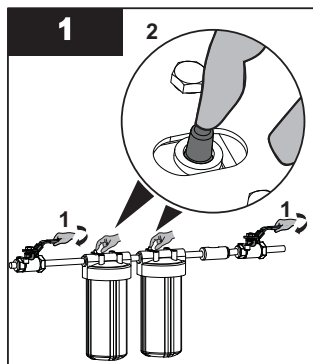

- Close all faucets and water supply.
- Press the pressure button to release the pressure from the cartridges.

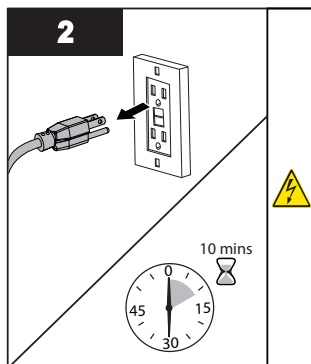

- Disconnect main power source and allow the unit to power down for 10 minutes.

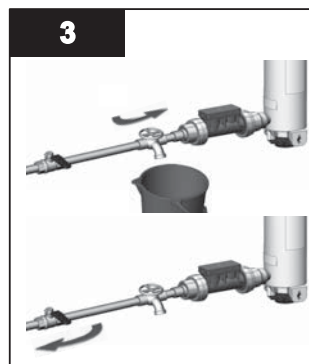

- Drain the water from the UV system.
- Close the water inlet after the water is drained.

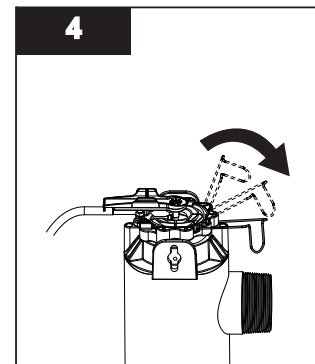

- Pinch wire form to release the lamp connector.

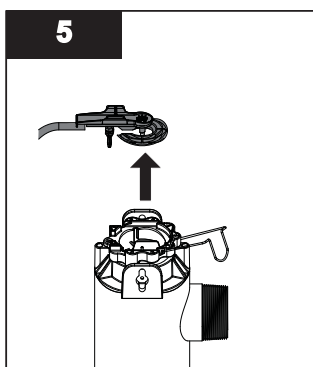

- Remove the lamp connector.

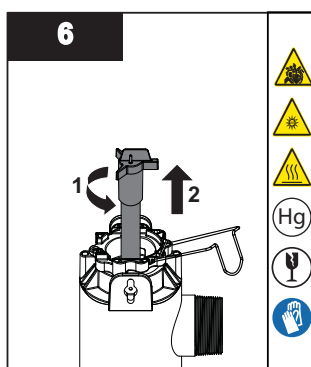

- Rotate and remove the UV lamp from the sleeve.

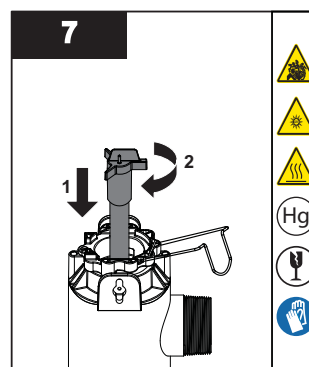

- Install and rotate the lamp into the sleeve assembly. Ensure to rotate the lamp completely.

Note: Do not touch glass with bare hands.

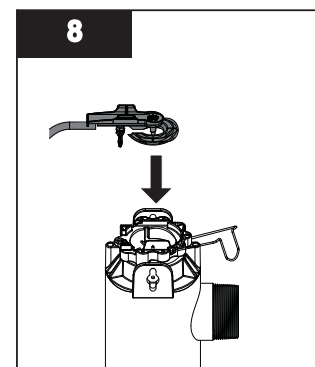

- Reinstall the lamp connector.

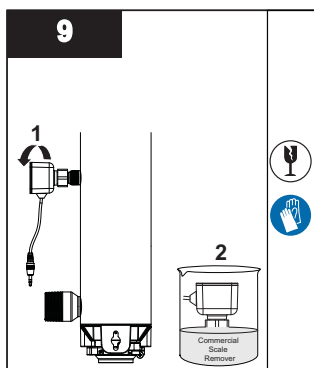

- Remove the UV sensor from the unit.
- Submerge the end of the sensor in the commercial scale remover for 30 minutes.
- Clean the sensor with a cotton swab and spray with water.
- For Basic model skip to step 10.

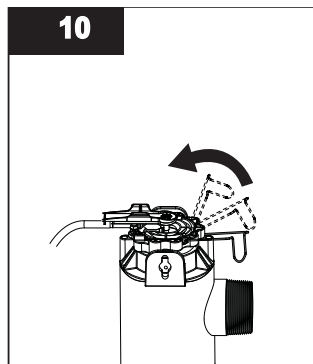

- Lock the wire form into position.

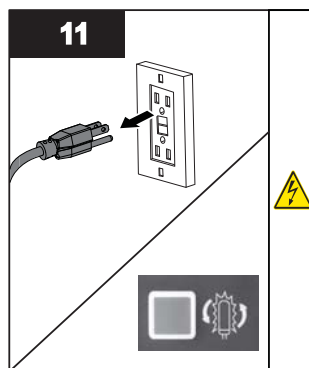

- Restore Power.
- Press and hold the “New Lamp” button for 5 seconds till you hear a beep.

Note: Lamp ignition may take up to 25 seconds.

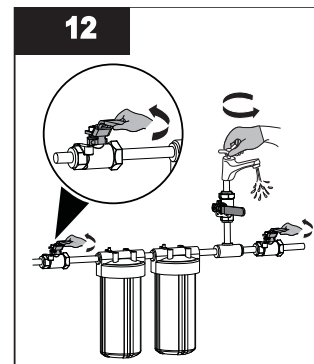

- Turn on the water supply.

Note: After replacing the UV lamp perform the disinfection procedure, refer to [Section 3.2](#).

4.2 Cleaning and Replacing Sleeve

Note: Minerals in the water slowly form a coating on the lamp sleeve. This coating must be removed because it reduces the amount of UV light reaching the water, thereby reducing disinfection performance. If the sleeve can not be cleaned, it must be replaced.

Prerequisites:

- Shut off water supply and drain all lines.
- Remove the UV lamp. Refer to [Section 4.1](#).

Procedure:

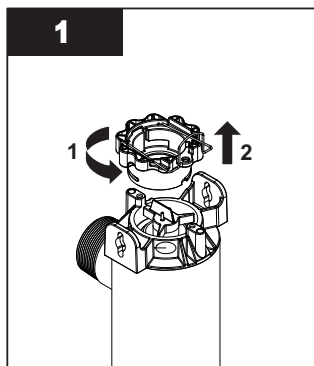

- Remove the sleeve bolt from top of the sleeve assembly.

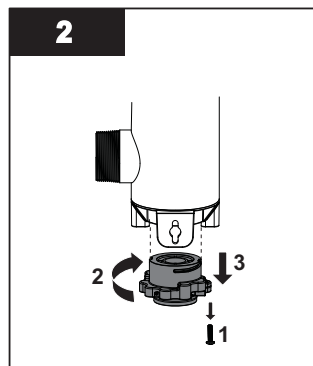

- Remove screw from the sleeve bolt.
- Remove the sleeve bolt at the bottom of the sleeve assembly.

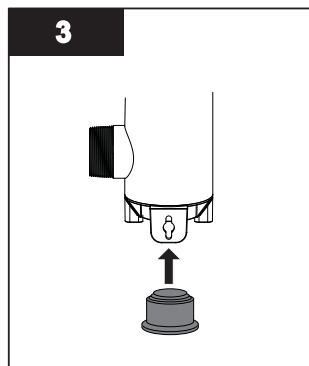

- Insert the sleeve removal tool into the bottom of the sleeve.

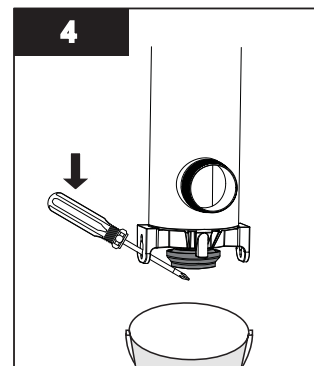

- Pry sleeve upward until it come loose.
- Place bucket under UV chamber, water will escape.

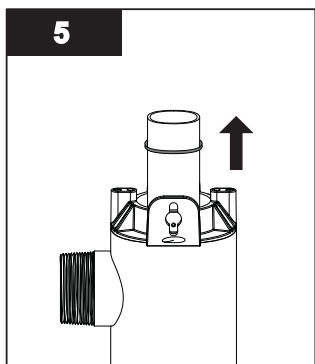

- Remove the sleeve.

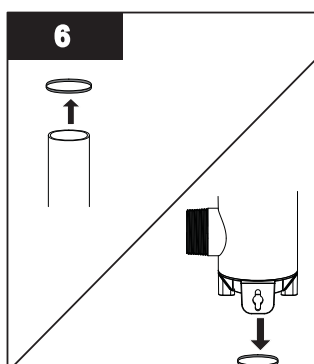

- Remove O-ring from top of the sleeve.
- Remove O-ring from bottom of the chamber (it may fall during sleeve removal process).

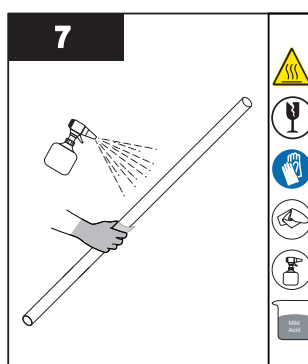

- Clean the sleeve with a cloth soaked in CLR, vinegar or some other mild acid and then rinse with water.
- Note:** If sleeve cannot be cleaned completely or it is scratched or cracked, then replace the sleeve.

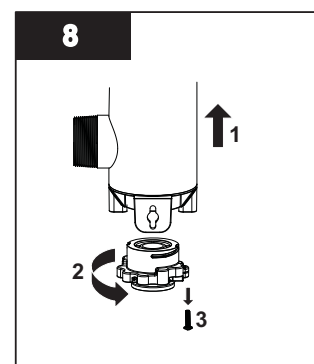

- Connect the sleeve bolt at the bottom of the sleeve assembly.

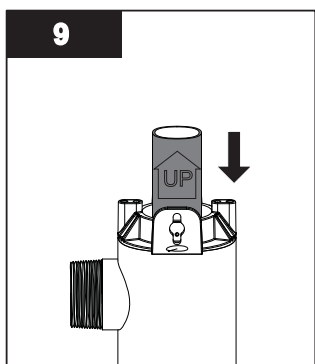

- Reinstall the sleeve with arrow pointing up.
- Note:** DO NOT rotate sleeve and touch glass with bare hands.

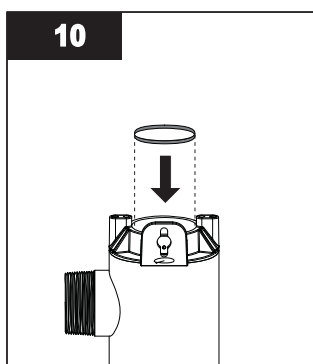

- Reinstall the new lubricated O-rings over the top end of the sleeve.

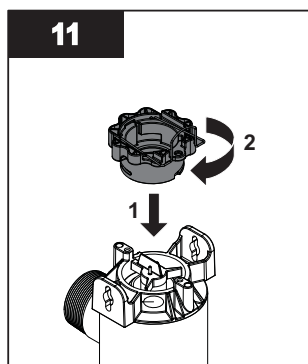

- Connect the sleeve bolt to the top of the sleeve assembly.

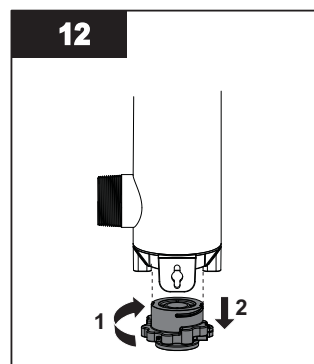

- Remove the sleeve bolt at the bottom of the sleeve assembly.

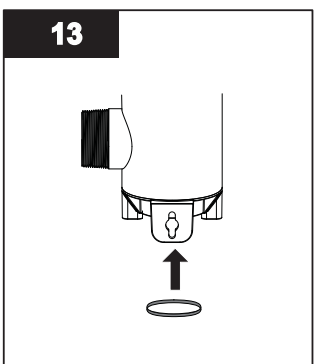

- Reinstall the O-ring at the bottom of the sleeve.

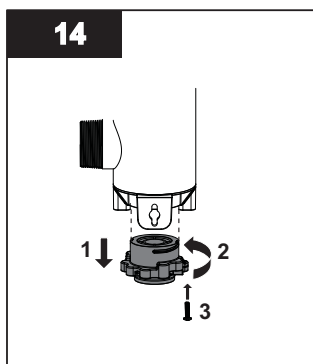

- Connect the sleeve bolt at the bottom.
- When service is complete, assemble the prerequisites in the reverse order of disassembly.

Note: After replacing the UV lamp or sleeve perform the disinfection procedure, refer to [Section 3.2](#).

4.3 Fuse Replacement

The system comes equipped with two functioning 250V 3A fuses. To access the fuses, first unplug system and disconnect the power cord from the controller. Remove the fuse door by pushing in the tab on one side using a knife or other tool and gently prying outwards. Repeat on the other side.

Procedure:

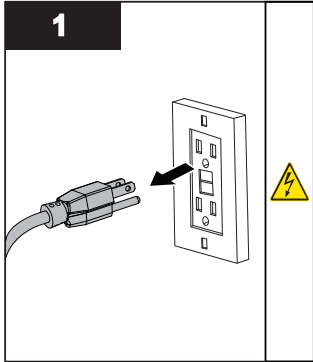

- Disconnect the controller to the system.

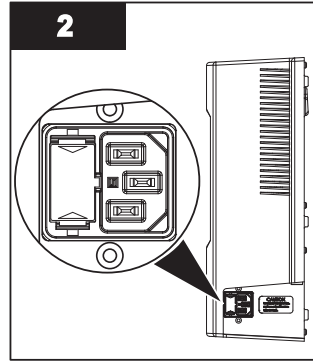

- Replace the fuse.

Caution: Double pole/Neutral fusing

4.4 Flow Meter Sensor Maintenance

Inspect Flow Meter Sensor periodically to ensure that there is no fouling and the paddle wheel spins freely with no resistance.

If paddle wheel does not spin freely or is loose the sensor should be returned for service and calibration. It is recommended that the Flow Meter Sensor be returned for calibration every two years to ensure accurate system operation.

Section 5 Operation

5.1 Control Panel

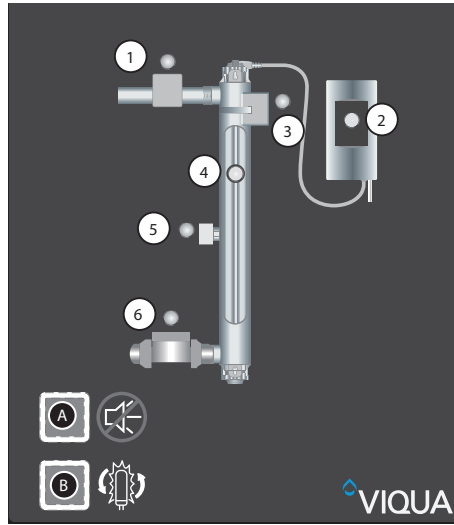

Figure 3 Control Panel

Buttons and Display				
Feature	Description	Function		
A	Mute	Press to silence audible alarm. When the alarm is due to the lamp's age, the mute button will silence the audible alarm for 7 days; this may be repeated up to a maximum of 4 times. After that, the button will silence for only 24 hours. When the alarm is due to any other issue, the mute button will silence the audible alarm for 24 hours.		
B	New Lamp	After installing a new lamp, press and hold for five seconds to reset Lamp timer.		
Indicator Lights				
LED	Green	Yellow	Flashing red	Solid red
1	Solenoid valve open (If equipped with solenoid)	Not applicable	Solenoid valve disconnected; reconnect. Solenoid coil damaged; replace coil (not entire solenoid).	Solenoid valve inactive (closed) due to failure of another component, in order to ensure safety of the water supply.
2	Operating normally Note: For Pro 10, 20, 30 Models, indicator will be flashing when system is in power savings mode.	Not applicable	Lamp connector not installed properly. Ensure lamp harness ground is inserted into chamber ground terminal. Controller failure, replace controller.	Lamp inactive due to controller failure.
3	Operating normally	Not applicable	Fan disconnected, reconnect. Fan turning slower than required; unplug system, clean blades using a Q- tip. Fan damaged, replace fan.	Not applicable.
4	Operating normally Note: During the lamp warm up, the indicator will flash	Warning: Lamp will require replacement shortly	Lamp disconnected; remove power, reconnect lamp and connect the controller. Lamp failure, replace lamp.	Lamp inactive due to controller failure. End of lamp reset required. Refer to Feature B in the above table.
5	UV dose is adequate and sensor is operating normally (For Plus Models only)	UV dose is near the minimum required	Sensor disconnected; unplug system, reconnect sensor and plug-in system again. Sensor failure. UV dose is below minimum required, see Low UV Alarm section.	Sensor inactive due to lamp or controller failure.
6*	Flow Meter operating normally	High flow UV dose inadequate, reduce flow to achieve higher dose levels	Flow meter sensor failure; service or replace sensor.	Low flow UV dose inadequate, service required.

* PRO10, PRO20, and PRO30 only

Section 6 Troubleshooting

Symptom	Possible Cause	Possible Solution
No power	GFCI and/or breaker tripped	Reset GFCI and/or breaker
	Controller fuse has blown	Replace controller fuse - see Fuse Replacement section (Refer Section 4.3).
	Transient voltage surge suppressor (TVSS) damaged	Replace TVSS
	Controller damaged	Replace controller and use a TVSS
GFCI or breaker repeatedly trips	Connection between lamp and lamp plug is wet	Clean and dry lamp pins and lamp plug, check unit for leaks or condensation
	Short-circuit in the electrical assembly	Replace controller
Leak at inlet or outlet	Threaded pipe fittings are leaking	Clean threads, reseal with Teflon tape and retighten
Leak detected from area of UV chamber	Condensation of moist air on cold chamber (slow accumulation)	Control humidity or relocate unit
	O-ring damaged, deteriorated or incorrectly installed	Inspect and replace if deteriorated
	Lamp/sleeve assembly not properly installed (too tight or not tight enough)	Ensure nut is turned completely
Alarm	Refer to Section 5.1 .	Refer to Section 5.1 .
System is operating but water tests reveal bacterial contamination	Equipment downstream of UV system is acting as a breeding ground for pathogens	Ensure UV is the last piece of treatment equipment
	Pathogens are residing in the distribution lines post-UV	Ensure all distribution lines have been disinfected with chlorine. Refer to Section 3.2 .
	Recontamination from pipe dead-ends	Remove any pipe dead-ends and flush with chlorine. Refer to Section 3.2 .
Flow Meter Sensor red status LED	Detect Flow Sensor not detecting flow	Increase Flow rate through meter
	Flow Meter Sensor not functioning	Flow Meter requires maintenance or replacement

6.1 LOW UV ALARMS (PRO and Plus Series Only)

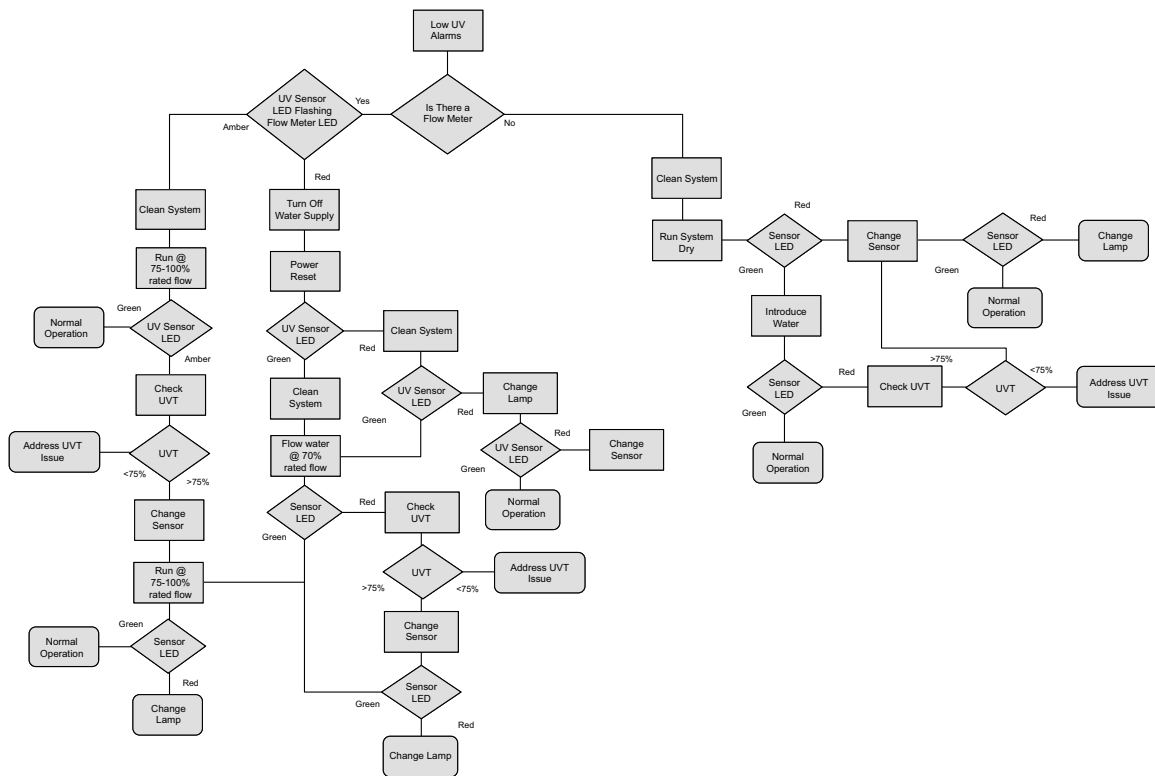

Figure 4 Low UV Alarms (PRO and Plus Series Only)





1. In some cases, short-term flows of low ultraviolet transmittance (UVT) water can be created following and during the regeneration cycle of a water softener, resulting in a sensor alarm. Flushing the UV system alleviates this condition until the softener goes through another regeneration cycle. In the longer term, the softener's settings must be modified. To flush the UV system, unplug the sensor, then open a tap downstream and let water run for two (2) minutes. Disinfect the water lines following the procedures outlined under "Disinfecting The Water Lines" in the Installation section.
2. Refer to Sleeve Cleaning And Lamp Replacement section of the Owner's Manual.
3. Contact your water treatment dealer to inquire about testing the UVT of your water.

Section 7 Specifications

General (All Models)	
Operating Parameters	
Maximum operating pressure	125 PSI (861 kPa)
Minimum operating pressure	15 PSI (103 kPa)
Maximum ambient air temperature	104 °F (40 °C)
Minimum ambient air temperature	32 °F (0 °C)
Maximum humidity	100%
Maximum hardness	120 ppm (7 grains per gallon)
Maximum iron	0.3 ppm
Minimum UVT	75%*
Installation	Vertical ONLY
Others	
Chamber material	316L SST
Rated service life of lamp	up to 2 years
* PRO50 has a minimum UVT rating of 85%	

	PRO10	PRO20	PRO30	PRO50	H, H+	K, K+
Rated flow for NSF Std 55, Class A	10 gpm (38 lpm) (2.2 m ³ /hr)	20 gpm (76 lpm) (4.5 m ³ /hr)	30 gpm (113 lpm) (6.8 m ³ /hr)	-	-	-
Rated flow dose of 30 mJ/cm ² @ 95% UVT	-	-	-	-	45 gpm (170 lpm) (10 m ³ /hr)	80 gpm (303 lpm) (18 m ³ /hr)
Rated flow dose of 40 mJ/cm ² @ 95% UVT	-	-	-	-	37 gpm (140 lpm) (8.4 m ³ /hr)	60 gpm (226 lpm) (13.6 m ³ /hr)
Rated flow for USEPA UVDGM 2006 protocol	-	-	-	50 gpm (189 lpm) (11.3 m ³ /hr)	-	-
Electrical						
Voltage	100-240V 50/60Hz	100-240V 50/60Hz	100-240V 50/60Hz	100-240V 50/60Hz	100-240V 50/60Hz	100-240V 50/60Hz
Max. current	2.5 Amp	2.5 Amp	2.5 Amp	2.5 Amp	2.5 Amp	2.5 Amp
Max. power consumption	120 Watts	160 Watts	230 Watts	230 Watts	160 Watts	230 Watts
Lamp power consumption	100 Watts	140 Watts	200 Watts	200 Watts	140 Watts	200 Watts
Port Size						
Inlet and outlet	Combo 1½" NPT, 1" FNPT	Combo 1½" NPT, 1" FNPT	Combo 1½" NPT, 1" FNPT	2" MNPT	Combo 1½" NPT, 1" FNPT	2" MNPT

Specifications

	PRO Series	Plus Series	Basic Series
Sensor	Yes	Yes	No
CoolTouch fan	Yes	Yes	Yes
Dynamic flow restrictor (PRO10, 20, 30 models only)	Yes	No	No
Communications ports (two, RJ45)	Yes	Yes	Yes
COMMcenter control package	Optional	Optional	Optional
Solenoid valve	Optional	Optional	Optional
Flow Meter Sensor (PRO10, 20, 30 Models only)	Yes	No	No
Controls			
Audible alarm mute button	Yes	Yes	Yes
New lamp button	Yes	Yes	Yes
Lamp age indicator	Yes	Yes	Yes
Lamp operation indicator	Yes	Yes	Yes
Controller operation indicator	Yes	Yes	Yes
Solenoid operation indicator	Yes	Yes	Yes
Fan operation indicator	Yes	Yes	Yes
Sensor reading indicator	Yes	Yes	No
NSF/ANSI certification (PRO10, 20, 30 models only)	 Standard 55 Class A	No	No
USEPA UVDGM 2006 (PRO50 model only)	Yes	No	No
Other Certifications			

Section 8 Manufacturer's Warranty

Our Commitment

VIQUA is committed to ensuring your experience with our products and organization exceeds your expectations. We have manufactured your UV disinfection system to the highest quality standards and value you as our customer. Should you need any support, or have questions about your system, please contact our Technical Support team at 1.800.265.7246 or technicalsupport@viqua.com and we will be happy to assist you. We sincerely hope you enjoy the benefits of clean, safe drinking water after the installation of your VIQUA disinfection system.

How to Make a Warranty Claim

Note: *To maximise the disinfection performance and reliability of your VIQUA product, the system must be properly sized, installed and maintained. Guidance on the necessary water quality parameters and maintenance requirements can be found in your Owner's Manual.*

In the event that repair or replacement of parts covered by this warranty are required, the process will be handled by your dealer. If you are unsure whether an equipment problem or failure is covered by warranty, contact our Technical Support team at 1.800.265.7246 or e-mail technicalsupport@viqua.com. Our fully trained technicians will help you troubleshoot the problem and identify a solution. Please have available the model number (system type), the date of purchase, the name of the dealer from whom you purchased your VIQUA product ("the source dealer"), as well as a description of the problem you are experiencing. To establish proof of purchase when making a warranty claim, you will either need your original invoice, or have previously completed and returned your product registration card via mail or online.

Specific Warranty Coverage

Warranty coverage is specific to the VIQUA range of products. Warranty coverage is subject to the conditions and limitations outlined under "[General Conditions and Limitations](#)".

Ten-Year Limited Warranty for VIQUA UV Chamber

VIQUA warrants the UV chamber on the VIQUA product to be free from defects in material and workmanship for a period of ten (10) years from the date of purchase. During this time, VIQUA will repair or replace, at its option, any defective VIQUA UV chamber. Please return the defective part to your dealer who will process your claim.

Five-Year Limited Warranty for Electrical and Hardware Components

VIQUA warrants the electrical (controller) and hardware components to be free from defects in material and workmanship for a period of five (5) years from the date of purchase. During this time, VIQUA will repair or replace, at its option, any defective parts covered by the warranty. Please return the defective part to your dealer who will process your claim.

One-Year Limited Warranty for UV lamps, Sleeves, and UV Sensors

VIQUA warrants UV lamps, sleeves, and UV Sensors to be free from defects in material and workmanship for a period of one (1) year from the date of purchase. During this time, VIQUA will repair or replace, at its option, any defective parts covered by the warranty. Your dealer will process your claim and advise whether the defective item needs to be returned for failure analysis.

Note: *Use only genuine VIQUA replacement lamps and sleeves in your system. Failure to do so may seriously compromise disinfection performance and affect warranty coverage.*

General Conditions and Limitations

None of the above warranties cover damage caused by improper use or maintenance, accidents, acts of God or minor scratches or imperfections that do not materially impair the operation of the product. The warranties also do not cover products that are not installed as outlined in the applicable Owner's Manual.

Parts repaired or replaced under these warranties will be covered under warranty up to the end of the warranty period applicable to the original part.

The above warranties do not include the cost of shipping and handling of returned items. The limited warranties described above are the only warranties applicable to the VIQUA range of products. These limited warranties outline the exclusive remedy for all claims based on a failure of or defect in any of these products, whether the claim is based on contract, tort (including negligence), strict liability or otherwise. These warranties are in lieu of all other warranties whether written, oral, implied or statutory. Without limitation, no warranty of merchantability or of fitness for a particular purpose shall apply to any of these products.

VIQUA does not assume any liability for personal injury or property damage caused by the use or misuse of any of the above products. VIQUA shall not in any event be liable for special, incidental, indirect or consequential damages. VIQUA's liability shall, in all instances, be limited to repair or replacement of the defective product or part and this liability will terminate upon expiration of the applicable warranty period.



425 Clair Rd. W, Guelph, Ontario, Canada N1L 1R1
t. (+1) 519.763.1032 • tf. (+1) 800.265.7246 (US and Canada only)
t. (+31) 73 747 0144 (Europe only) • f. (+1) 519.763.5069
e-mail: info@viqua.com
www.viqua.com